

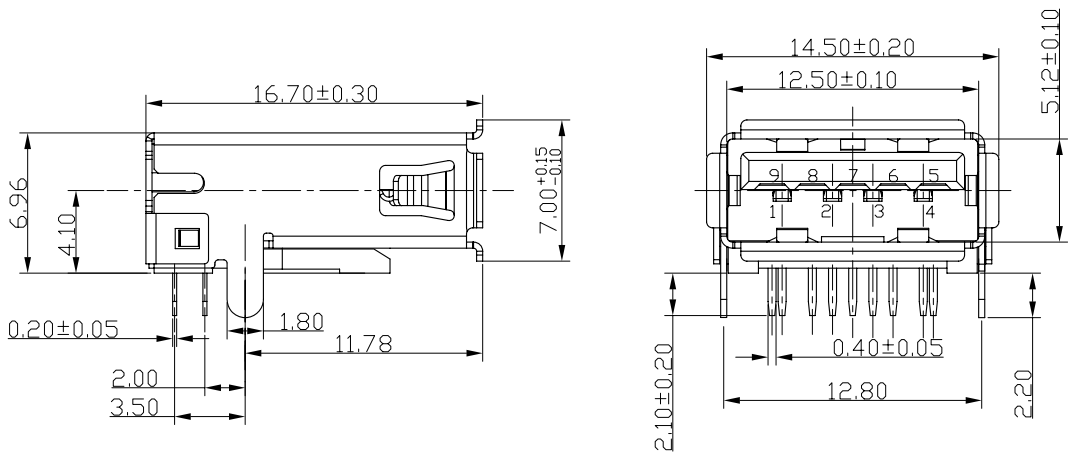

DATE	DR.BY	ECN.NO.	DESCRIPTION	MARK	VER.
3/29'14			NEW DWG		AO



NOTE:  
 1. MATERIAL:  
 1.1 INSULATOR:HIGH TEMPERATURE PLASTIC  
 1.2 CONTACT:BRONZE  
 1.3 SHELL:BRASS  
 2. ELECTRICAL CHARACTERISTICS:  
 2.1 CONTACTRESISTANCE:30mΩ MAX  
 2.2 CONTACT CURRENT RATING:1.5A  
 2.3 DIELECTRIC WITHSTANDING VOLTAGE:100 V R. M. S.  
 2.4 INSULATION RESISTANCE 100 MΩ MIN  
 2.5 OPERATING TEMPEROTURE:-20° C ~ 60° C  
 3 MECHANICAL CHARACTERISTICS:  
 3.1 MATING FORCE:3.57kgf MAX  
 3.2 UNMATING FORCE:1.02kgf MIN  
 3.3 DURABILITY:MANDATORY:1,500 CYCLES  
 4. PLATING  
 4.1 ITERMINAL:  
 50u" MIN NICKEL ALL OVER  
 80u"MIN Tin ON SOLDER AREA  
 (1~30)u"Au ON CONTACT AREA  
 4.2 SHELL:50u"MIN.NICEL ALL OVER  
 5. PART NO.  
 122-F092G11 X -U13

T: 半金雾锡1u"    K: 半金雾锡5u"  
 M: 半金雾锡15u"    N: 半金雾锡30u"

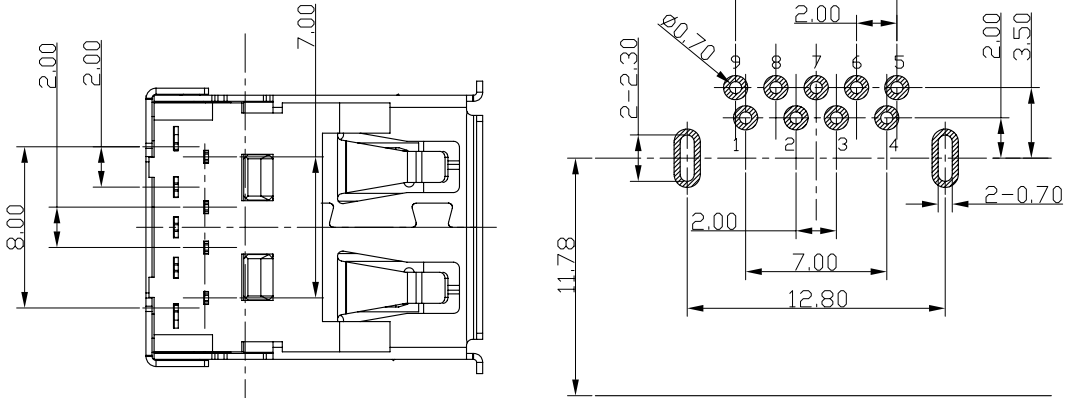

RECOMMENDED PCBA LAYOUT  
(TOLERANCE±0.05)

Pin NUMBER	SIGNAL NAME
1	VBUS
2	D-
3	D+
4	GND
5	StdA_SSRX-
6	StdA_SSRX+
7	GND_DRAIN
8	StdA_SSTX-
9	StdA_SSTX+
Shell Shield	

-TOLERANCES- UNLESS OTHERWISE SPECIFIED 公差参考表		东莞市龙科电子科技有限公司 DONGGUAN LONGKE ELECTRONICS CO.,LTD.:							
		TITLE: USB 3.0 AF板上90度DIP, 外 产品品名: 壳卷边直脚							
X.X	±0.25	X.X°	±3.00°	APPD: 核准:	PRODUCT NO: 产品料号: 122-F092G11X-U13				
X.XX	±0.20	X.XX°	±1.00°	CHECK:dd 校对:	DATE	SCALE	UNIT	TYPE	PAGE
X.XXX	±0.10	X.XXX°	±0.500°	DRAW: 绘图: 范小飞	2015.03.25	1:1	mm	CD	1/1