

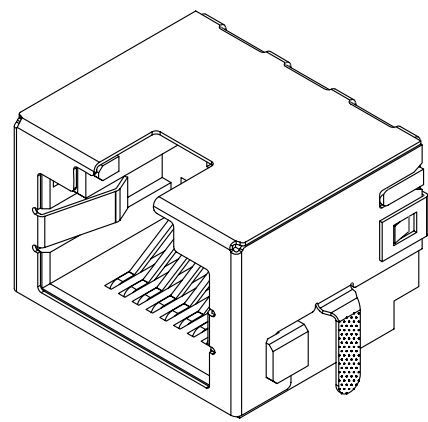

DATE	DR.BY	ECN.NO.	DESCRIPTION	MARK	VER.
04/21'16	范小飞		制程需要,放宽尺寸公差	△	AO

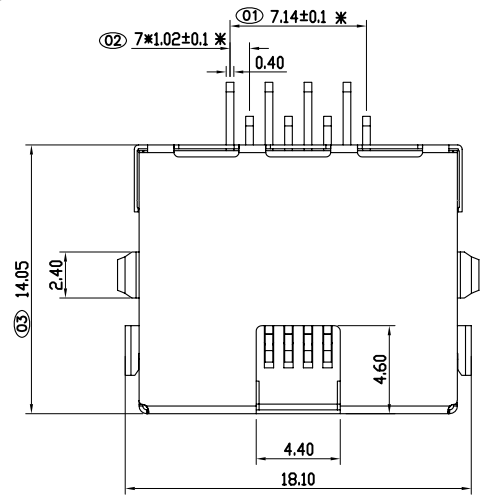

NOTE:
 1.MATERIAL:
 HOUSING:THERMOPLASTIC BLACK UL94V-0
 RJ CONTACT: PHOSPHER BRONZE T=0.30mm
 SHELL: COPPY ALLOY T=0.20mm
 2.FINISH:
 RJ CONTACT: AU/1u" SN/100U" NI/50U"
 SHELL: NI PLATED
 3.MECHANICAL CHARACTERISTICS:
 INSERTION FORCE: 22N MAX
 REMOVAL FORCE(WITHOUT PLUG LOCK):22N MAX
 PLUG LOCKING RETENTION FORCE: 50N MIN /60 sec
 DURABILITY:750 TIMES
 4.OPERATING TEMPERATURE: 0 °C~70 °C

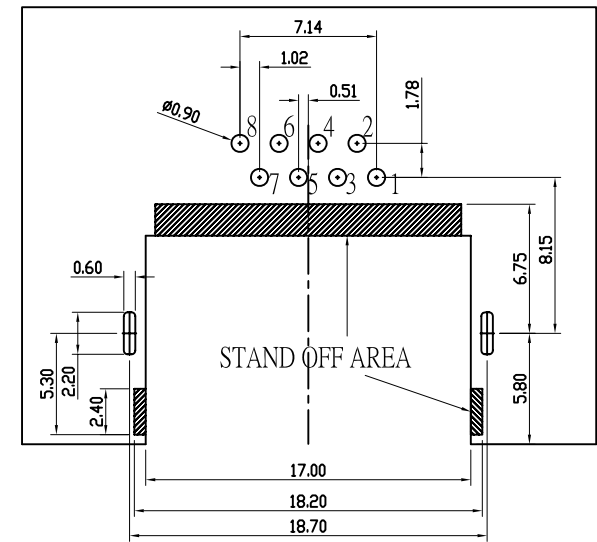
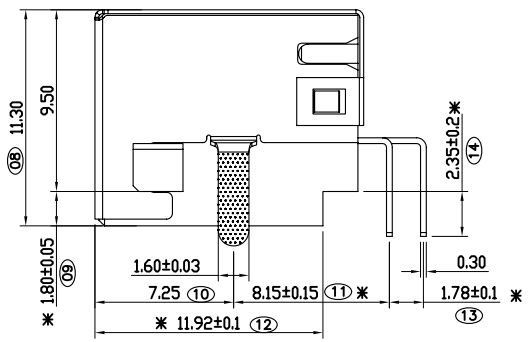
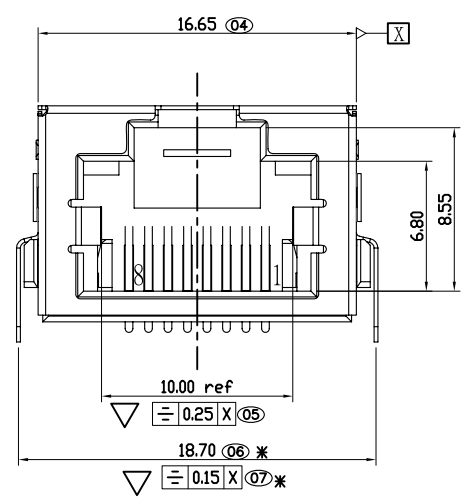

PCB LAYOUT TOP VIEW
 TOL:±0.05(THICKNESS=1.60)

-TOLERANCES- UNLESS OTHERWISE SPECIFIED 公差参考表		东莞市龙科电子科技有限公司 DONGGUAN LONGKE ELECTRONICS CO.,LTD :						
X.X	±0.15	X.X°	±3.00°	TITLE: 产品品名: 沉板1.8无灯无弹片				
X.XX	±0.10	X.XX°	±1.00°	APPD: 核准:				
X.XXX	±0.010	X.XXX°	±0.500°	PRODUCT NO: 产品料号: 241-F082G310-B10				
				DATE	SCALE	UNIT	TYPE	PAGE
				2014.04.23	1:1	mm	CD	1/1