

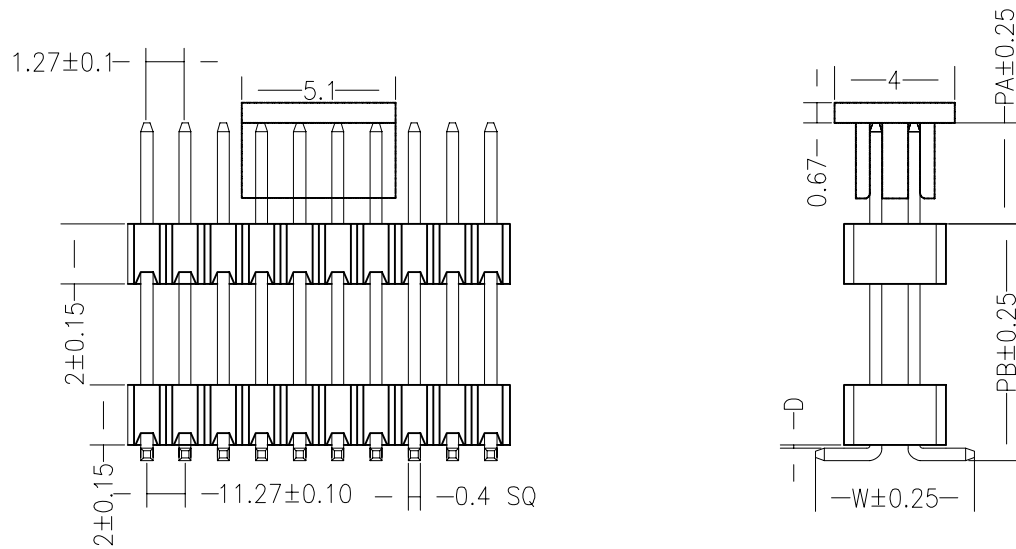

DATE	DR.BY	ECN.NO.	DESCRIPTION	MARK	VER.
07/18'16	何俊勇		NEW DWG_		AO

Recommended P.C.B Layout (Top Side)
(PCB BOARD TOLERANCE ±0.05)

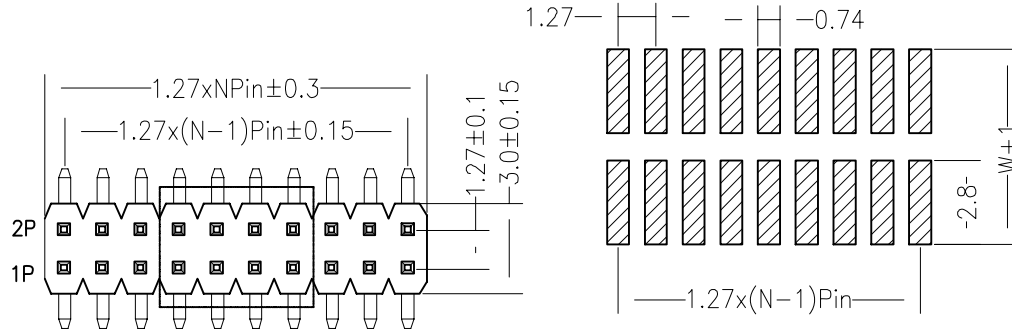

SPECIFICATIONS

Rated Current: 1.0AMP
 Contact Resistance: 20mΩ Max
 Withstand Voltage: 500V AC/DC
 Insulation Resistance: 1000MΩ Min
 Operation Temperature: -40°C to +105°C

Contact Material: Brass
 Contact Plating: Au or Sn Over Ni
 Insulator Material: Polyester (UL94V-0)
 Standard: PA6T
 Max. Processing Temp: 230°C for 30-60 seconds
 (260°C for 10 seconds)

PART NO.
131-M XX 36460-B11

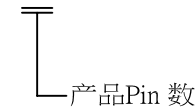

Dimension antitheses list					
ITEM	PA	PB	W	D	L
Standard	4.00	10.00	5.30	0.10	15.60

-TOLERANCES- UNLESS OTHERWISE SPECIFIED 公差参考表			东莞市龙科电子科技有限公司 DONGGUAN LONGKE ELECTRONICS CO.,LTD.:						
					TITLE: PH=1.27mm,H=2.0mm SMT 产品品名: 带夹持盖				
±0.25	X.X°	±3.00°	APD: 刘威 核准:		PRODUCT NO: 产品料号: 131-MXX36460-B11				
±0.20	X.XX°	±1.00°	CHECK:dd 校对: 范小飞		DATE	SCALE	UNIT	TYPE	PAGE
±0.10	X.XXX°	±0.500°	DRAW: 何俊勇 绘图:		2016.07.18	1:1	mm	CD	1/1