

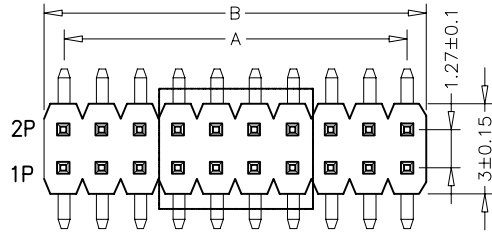

DATE	DR.BY	ECN.NO.	DESCRIPTION	MARK	VER.
07/18'16	何俊勇		NEW DWG		AO



NOTES:

MATERIAL:

HOUSING:PA6T UL 94V-0. BLACK,COLOR.

CONTACT:COPPER ALLOY. C2680

FINISH:

CONTACT:PLATED GOLD FLASH, 50u" MIN

NICKEL UNDER PLATED ALL OVER.

SPECIFICATION

WITHSTANDING VOLTAGE: AC 300V MIN

CURRENT RATING:1.0 AMP

INSULATION RESISTANCE:1000MΩ Min

CONTACT RESISTANCE:20MΩ

OPERATING TEMPERATURE -40℃ TO +105℃

INSERTION FORCE

RETENTION FORCE BEFOR SOLDERING >=0.8KGF

RETENTION FORCE AFTER SOLDERING >=0.2KGF

PART NO.

131-M XX 36460-BA1

产品Pin数

PIN NO.	DIM A	DIM B	PIN NO.	DIM A	DIM B
2*2 PIN	1.27	2.54	2*12 PIN	13.97	15.24
2*3 PIN	2.54	3.81	2*13 PIN	15.24	16.51
2*4 PIN	3.81	5.08	2*14 PIN	16.51	17.78
2*5 PIN	5.08	6.35	2*15 PIN	17.78	19.05
2*6 PIN	6.35	7.62	2*16 PIN	19.05	20.32
2*7 PIN	7.62	8.89	2*17 PIN	20.32	21.59
2*8 PIN	8.89	10.16	2*18 PIN	21.59	22.86
2*9 PIN	10.16	11.43	2*19 PIN	22.86	24.13
2*10 PIN	11.43	12.7	2*20 PIN	24.13	25.4
2*11 PIN	12.7	13.97			

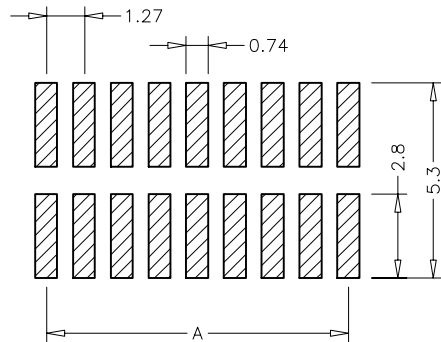
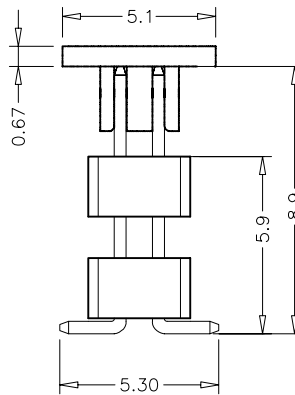
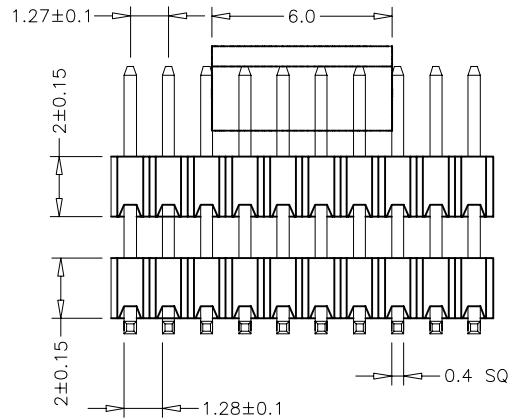

RECOMMEND P.C.B LAYOT

-TOLERANCES- UNLESS OTHERWISE SPECIFIED 公差参考表			东莞市龙科电子科技有限公司 DONGGUAN LONGKE ELECTRONICS CO.,LTD :						
±0.25	X.X°	±3.00°			TITLE: PH=1.27mm,H=8.9mm SMT 产品品名: 带夹持盖				
±0.20	X.XX°	±1.00°	APPD: 核准:	刘威	PRODUCT NO: 产品料号: 131-MXX36460-BA1				
±0.10	X.XXX°	±0.500°	CHECK: 校对:	dd 范小飞	DATE	SCALE	UNIT	TYPE	PAGE
			DRAW: 绘图:	何俊勇	2016.07.18	1:1	mm	CD	1/1