



DATE	DR.BY	ECN.NO.	DESCRIPTION	MARK	VER.
02/13'14	ming		NEW DWG		AO

NOTES:

MATERIAL:

HOUSING:PA6T UL 94V-0.  
CONTACT:COPPER ALLOY.

FINISH:

CONTACT:PLATED GOLD FLASH, 50u" MIN  
NICKEL UNDER PLATED ALL OVER.

SPECIFICATION

CURRENT RATING : 1.5 AMP MAX.  
DIELECTRIC WITHSTAND VOLTAGE :  
600V AC R.M.S. FOR 1 MINTUE.  
INSULATION RESISTANCE : 1,000MΩ MIN.AT 500V DC.  
OPERATING TEMPERATURE : -55°C TO +105°C.  
INSERTION FORCE  
RETENTION FORCE BEFOR SOLDERING >=0.8KGF  
RETENTION FORCE AFTER SOLDERING >=0.2KGF

PART NO.

130-M XX 28240-B03

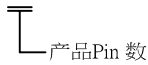

产品Pin 数

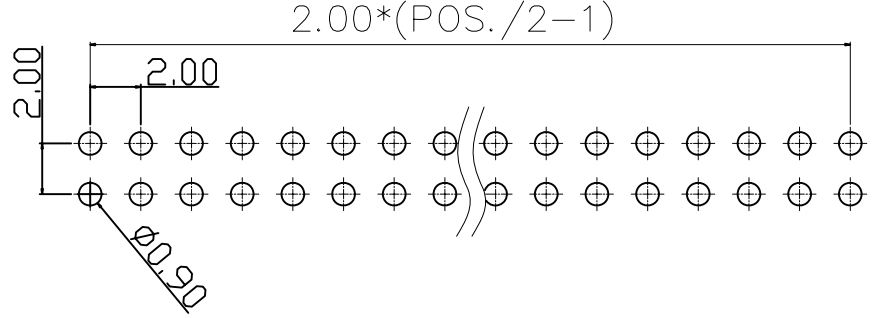
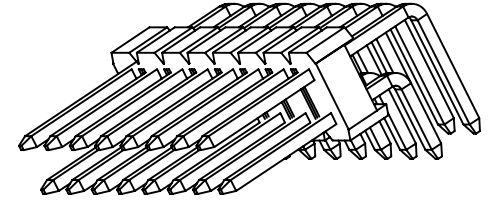
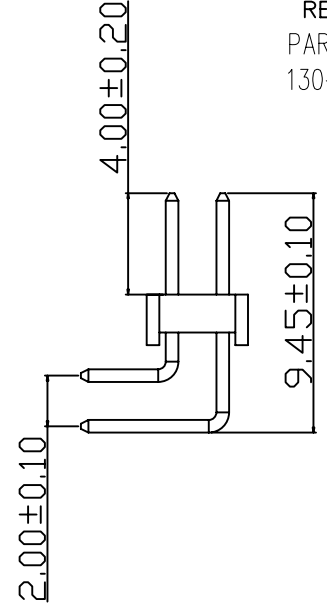
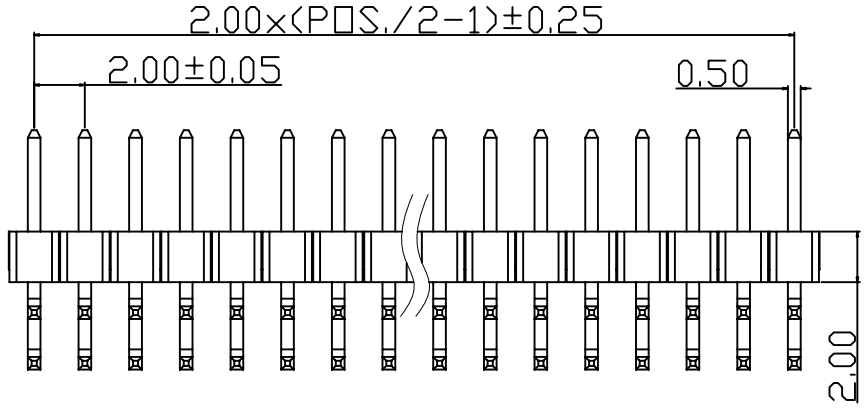
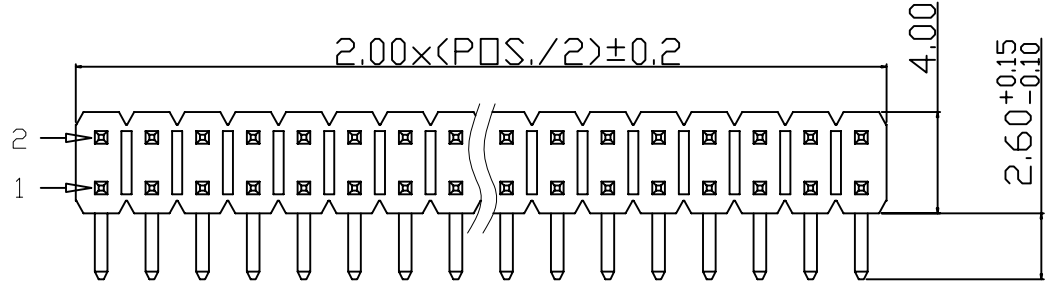

RECOMMEND P.C.B LAYOUT

-TOLERANCES-		DONGGUAN LONGKE ELECTRONICS CO.,LTD :	
UNLESS OTHERWISE SPECIFIED		东 莞 市 龙 科 电 子 科 技 有 限 公 司	
公差参考表		DONGGUAN LONGKE ELECTRONICS CO.,LTD :	
X.X ±0.25	X.X° ±3.00°	TITLE: 2.00MM 双排排针	
X.XX ±0.20	X.XX° ±1.00°	产品品名: DIP 90°	
X.XXX ±0.010	X.XXX° ±0.500°	PRODUCT NO: 130-MXX28240-B03	
APPD: 核准:		DATE	SCALE
CHECK:dd 校对:		UNIT	TYPE
DRAW: 绘图:		2014.02.13	1:1
		mm	CD
			1/1