

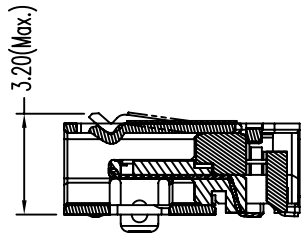

DATE	DR.BY	ECN.NO.	DESCRIPTION	MARK	VER.
12/23'13	VICKY		NEW DWG		AO

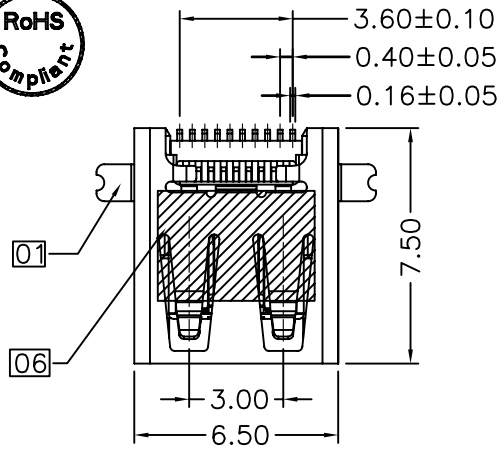

SECTION VIEW

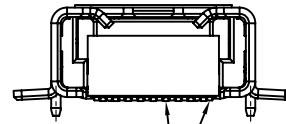
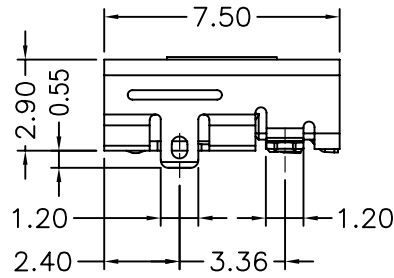
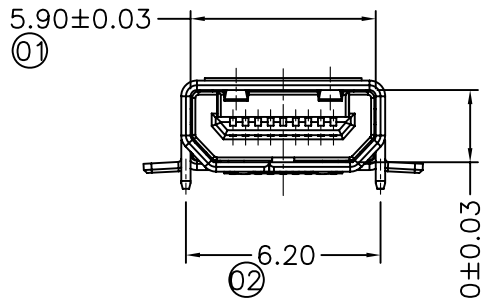

NOTE:
 1.MATERIAL AND FINISH SEE THE TABLE.
 2.MECHANICAL CHARACTERISTICS
 INSERTION FORCE: 44.1N MAX
 EXTROCTION FORCE: 5N MIN(AFTER 5000 CYCLES 3N MIN.), 25N MAX.
 MATING CYCLE:5000 CYCLES
 3.ELECTRICAL CHARACTERISTICS
 RATING CURRENT: 0.3A
 RATING VOLTAGE: 40V
 CONTACT RESISTANCE: 10 MILLOHMS OHMS MAX (EXCLDING CONDUCTOR RESISTANCE)
 INSULATION RESISTANCE:
 a, UNMATED: 100M OHMS MIN AT 500 VDC
 b, MATED: 10M OHMS MIN AT 150 VDC
 DIELECTRIC WITHSTANDING VOLTAGE:
 a, UNMATED: 250V AC(RMS)
 b, MATED: 150V AC(RMS)
 4.MARKED ⊛ DIMENSION SHOULD BE MEASURED BY QIP;

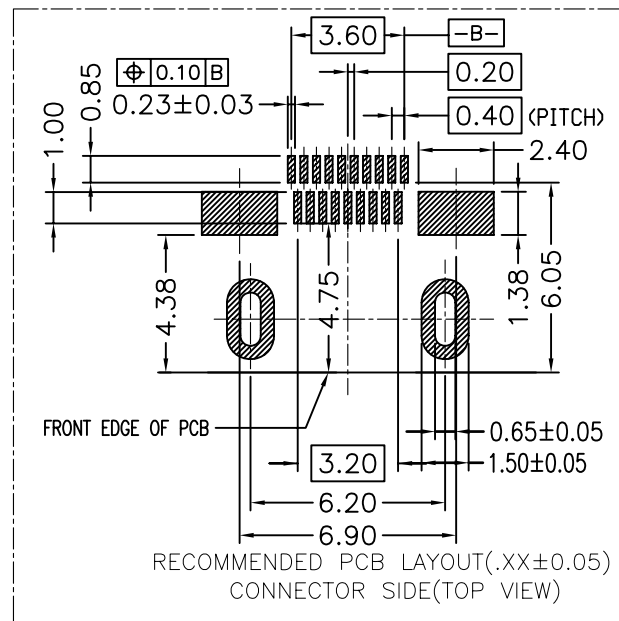
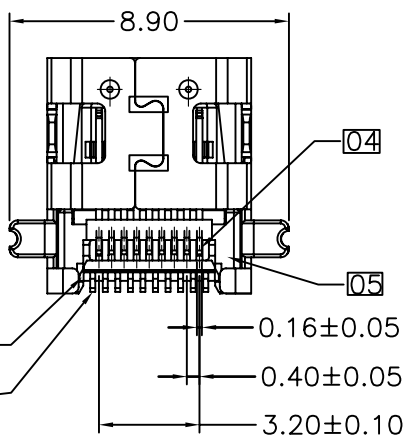
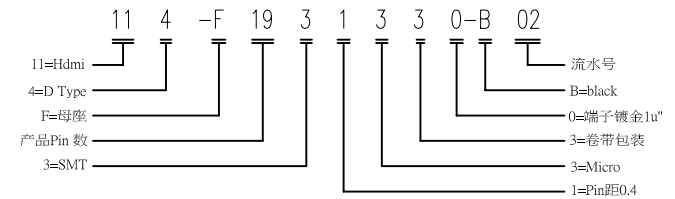

NO.	NAME	MATERIAL	FINISH/COLOR	NOTE
01	SHELL	STAINLESS STEEL	MATTE TIN UNDER PLATED	t=0.30
02	10PinTERMINAL	COPPER ALLOY	GOLD PLATING ON CONTACT AREA SEE PART NO.1u"MIN. PLATED ON SOLDER TAILS	t=0.12
03	10Pin InsertMolding	LCP+30%G.F	UL94V-0 BLACK	
04	9PinTERMINAL	COPPER ALLOY	GOLD PLATING ON CONTACT AREA SEE PART NO.1u"MIN. PLATED ON SOLDER TAILS	t=0.12
05	9Pin InsertMolding	LCP+30%G.F	UL94V-0 BLACK	
06	MYLAR			

-TOLERANCES-
UNLESS OTHERWISE SPECIFIED
公差参考表

X.X	±0.25	X.X°	±3.00°
X.XX	±0.20	X.XX°	±1.00°
X.XXX	±0.10	X.XXX°	±0.500°

APPD: 核准:
CHECK:dd 校对:
DRAW: 绘图:

东 莞 市 龙 科 电 子 科 技 有 限 公 司
DONGGUAN LONGKE ELECTRONICS CO.,LTD :

TITLE: HDMI-D-19P-F
产品品名: Insertmold Shell 前插后贴

PRODUCT NO:
产品料号: 114-F1931330-B02

DATE	SCALE	UNIT	TYPE	PAGE
2013.12.20	1:1	mm	CD	1/1