

DATE	DR.BY	ECN.NO.	DESCRIPTION	MARK	VER.
06/06'16	何俊勇		NEW DWG		AO

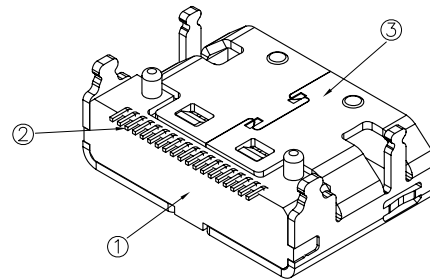
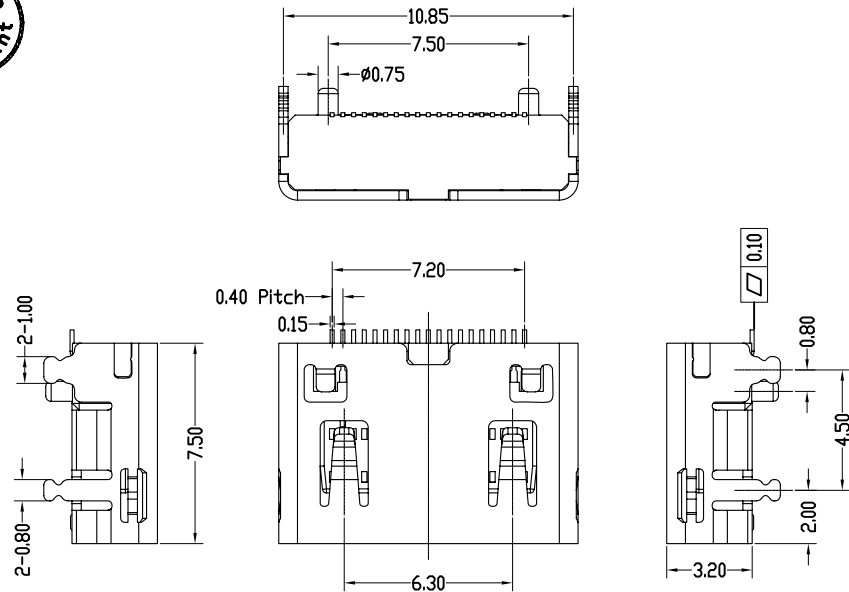

3D VIEW

NOTES:

- 1.) MATERIAL:
 - 1-1. HOUSING:LCP,UL 94V-0,COLOR:BLACK;
 - 1-2. CONTACT:COPPER ALLOY;
 - 1-3. SHELL:COPPER ALLOY;
- 2.) FINISH:
 - 2-1. CONTACT: PLATING AU OVERALL
PLATING NI OVERALL
 - 2-2. SHELL: PLATING AU OVERALL
PLATING NI OVERALL
- 3.) SPECIFICATIONS:
 - 3-1. VOLTAGE RATING: 40V
 - 3-2. CURRENT RATING: 0.5A
 - 3-3. INSULATION RESISTANCE: 100MEG.OHM MIN
 - 3-4. CONTACT RESISTANCE: 30MILL.OHM MAX
 - 3-5. OPERATION TEMPERATURE: -20° TO +85°
 - 3-6. INSERT FORCE: 25N MAX
 - 3-7. EXTRACT FORCE: 7N MIN
 - 3-8. DURABILITY: 5000 CYCLES

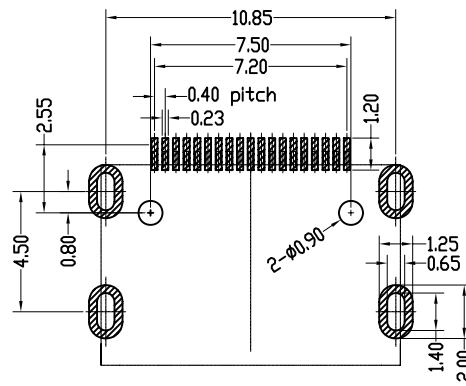
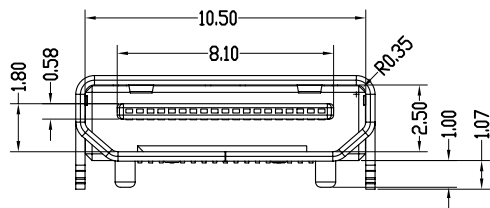

RECOMMEND PCB LAYOUT
PCB TOLERANCE:±0.05

PART NO.

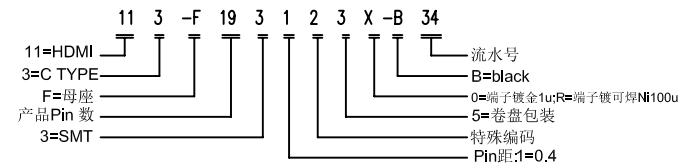

③	SHELL	C2680 T=0.35mm	Plating AU On The External Surface Plating NI Inner Surface Over All	1
②	CONTACT	C2680 T=0.15mm	Plating AU On The External Surface Plating NI Inner Surface Over All	19
①	HOUSING	HIGH TEMPERATURE THERMOPLASTICS	UL 94V-0	BLACK 1
NO	ITEM	MATERIAL	SPECIFICATION	COLOR DOSAGE

-TOLERANCES- UNLESS OTHERWISE SPECIFIED 公差参考表		东莞市龙科电子科技有限公司 DONGGUAN LONGKE ELECTRONICS CO.,LTD :				
X.X ±0.25	X.X° ±3.00°			TITLE: 产品品名: MINI HDMI 19Pin SMT		
X.XX ±0.20	X.XX° ±1.00°	APPD: 核准:		PRODUCT NO: 产品料号: 113-F1931230-B34		
X.XXX ±0.10	X.XXX° ±0.500°	CHECK:dd 校对: 范小飞		DATE	SCALE	UNIT
		DRAW: 绘图: 何俊勇		2016.06.06	1:1	mm
				TYPE	CD	PAGE
				1/2		