

NOTE:
 1.MATERIAL AND FINISH SEE THE TABLE.
 2.MECHANICAL CHARACTERISTICS
 INSERTION FORCE: 44.1N MAX
 EXTROCTION FORCE: 9.8N MIN, 39.2N MAX
 MATING CYCLE:10000 CYCLES
 3.ELECTRICAL CHARACTERISTICS
 RATING CURRENT: 0.5A
 RATING VOLTAGE: 40V
 CONTACT RESISTANCE: 10 MILLOHMS OHMS MAX (EXCLDUING CONDUCTOR RESISTANCE)
 INSULATION RESISTANCE:
 a, UNMATED: 100M OHMS MIN AT 500 VDC
 b, MATED: 10M OHMS MIN AT 150 VDC
 DIELECTRIC WITHSTANDING VOLTAGE:
 500V AC/1MINUTE
 OPERATING TEMPERATURE: -20°C--+85°C
 STORAGE TEMPERATURE: -20°C--+65°C

料号信息说明:
 LK-A111910-X-XX-X
 类别 A:成品
 系列码 11:HDMI-A/F
 PIN数码 19:19PIN
 流水码: 10
 同类变动码:
 E: 外壳有 "TC" LOGO, 端子尾部雾锡80u"Min
 F: 外壳无 "TC"LOGO, 端子尾部镀金1u" Min
 包装 R:TAPE & REEL
 T:TRAY
 端子接触区电镀
 01: Au 1u"
 03: Au 3u"
 05: Au 5u"
 10: Au 10u"
 15: Au 15u"
 30: Au 30u"

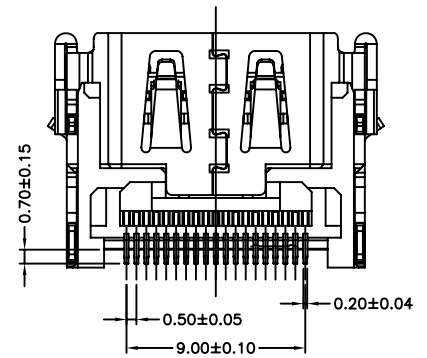

Item	Title	Material	Dispose	Remark
1	Terminal	Copper Alloy	Mating Area: Au 1u"	t=0.20
			Solder Tails: Au	
			Mating Area: Au 1u"	
2	InsertMolding	LCP	UL94V-0	Black
			Solder Tails: Sn	
3	Shell	Copper Alloy	Ni:50u" Min.	t=0.50

DATE	DR.BY	ECN.NO.	DESCRIPTION	MARK	VER.
3/18'14	ming		外壳DIP脚长度由1.9变更为2.7mm		A0
11/13'15	FXF		端子焊脚镀金改为镀锡, 加强爬锡焊锡性		A1

-TOLERANCES-
 UNLESS OTHERWISE SPECIFIED
 公差参考表

X.X	±0.25	X.X"	±3.00"
X.XX	±0.20	X.XX"	±1.00"
X.XXX	±0.010	X.XXX"	±0.500"

东莞市龙科电子科技有限公司
 DONGGUAN LONGKE ELECTRONICS CO.,LTD :

TITLE: HDMI-A/F CONN. SMT TYPE
 产品品名: SMT TYPE

PRODUCT NO: LK-A111910-E-01-R
 产品料号: LK-A111910-E-01-R

DATE	SCALE	UNIT	TYPE	PAGE
2013.12.20	1:1	mm	CD	1/1