

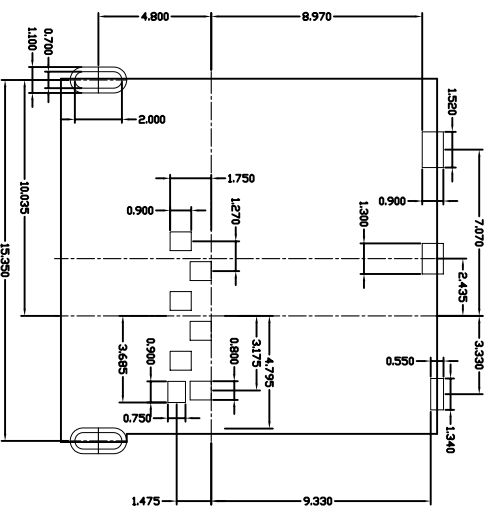

DATE	DR.BY	ECON.NO.	DESCRIPTION	MARK	VER.
3/29'14			NEW DWG		A0

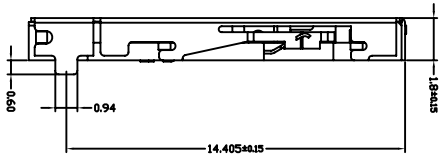

RECOMMENDED PCB LAYOUT
TOL:(±0.05)

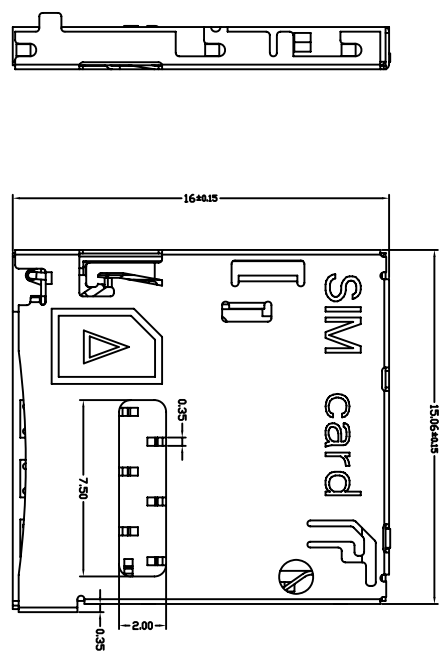
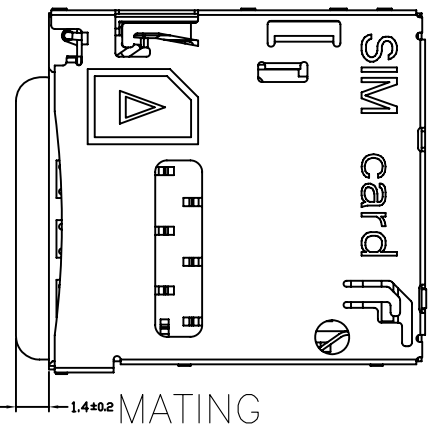
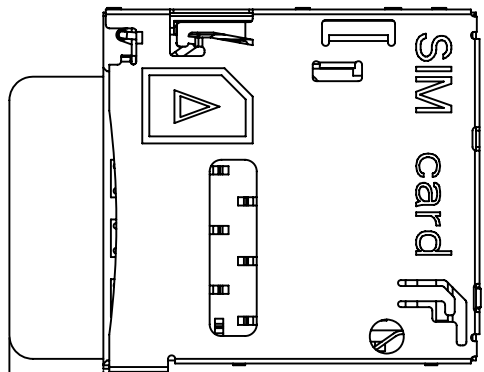
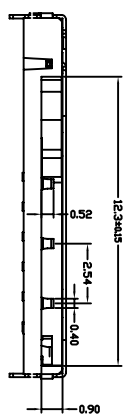
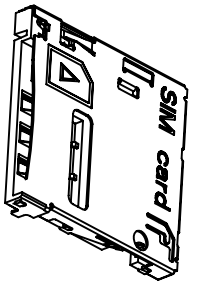

NOTE:
1.MATERIAL:
A. HOUSING: LCP, UL 94-V0 COLOR: BLACK.
B. CONTACT: PHOSPHOR BRONZE T=0.12mm
C. SHELL: SUS 304 1/2H T=0.15mm

2. PLATING: Underplate: 50~80u" Nickel
Contact area: 3~30u" Gold
Solder tails area: 3u" Gold
Shell: 50~80u" Nickel

3.ELECTRICAL CHARACTERISTICS:
A. Operating voltage: 30V(AC/DC).
B. Current rating: 1AMP MAX
C. Operating temperature: 20°c~+85°c
D. Insulation resistance: 1000M ohme min. at 200VDC.
E. Dielectric withstanding voltage: 500 VAC/1minute.
F. Contact resistance: 30m ohme max.

SHELL(GD) NORMAL=CLOSE
DETECT CARD INSERTING=OPEN



-TOLERANCES- 公差参考表		UNLESS OTHERWISE SPECIFIED	
X.X	±0.25	X.X°	±3.00°
X.XX	±0.20	X.XX°	±1.00°
X.XXX	±0.10	X.XXX°	±0.500°

APPD:	核准:	APPD:	核准:
CHECK:dd	校对:	CHECK:dd	校对:
DRAW':	范小飞	DRAW':	范小飞

TITLE:	产品品名:	PUSH MICRO SIM 1.8H		
PRODUCT NO:	产品料号:	197-F063G23H-B07		
DATE	SCALE	UNIT	TYPE	PAGE
2015.03.25	1:1	mm	CD	1/1

东莞市龙科电子科技有限公司
DONGGUAN LONGKE ELECTRONICS CO.,LTD.



DATE	DR. BY	ECN. NO.	DESCRIPTION	MARK	VER.
3/29'14			NEW DWG		AO

PACKING NOTES:

1. PRIMARY PACKING: 1300PCS/REEL;
2. SECONDARY PACKING: 10 REEL/CARTON (3KPCS/CARTON)
3. PEELING RESISTANCE: 30gf~100gf
4. PEELING ANGLE: 165°~180°
5. PEELING SPEED: 300mm/minutes.

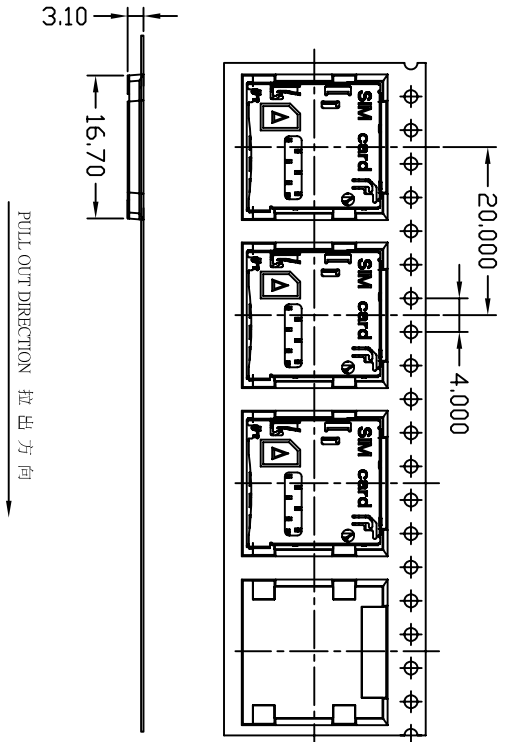
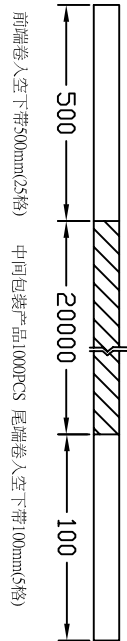
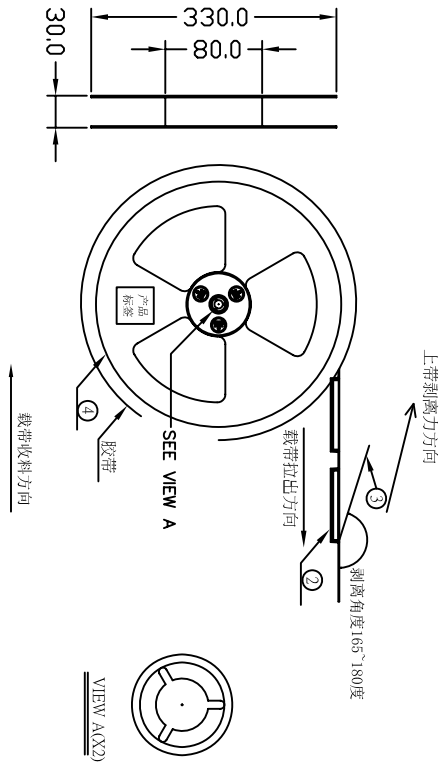
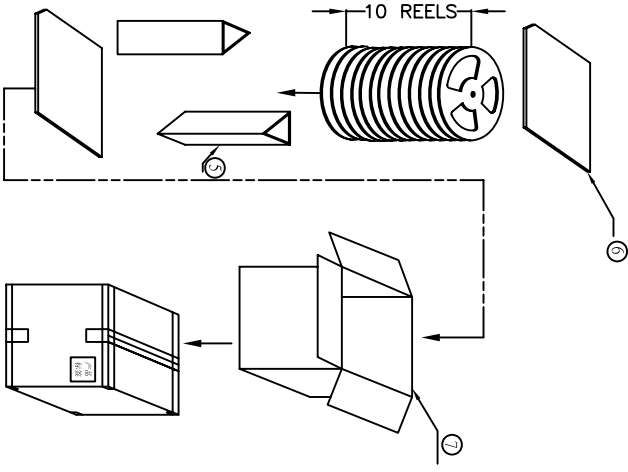

TABLE:

NO.	NAME	P/N	SPEC.	REMARK
①	成品		PUSH MICRO SIM CARD 1.8H	1000PCS/R
②	下带(载带)	P10-10007-4002	PET料 透明色, W=24mm, P=20mm, T=0.3mm.	20.6M/1000PCS
③	上带(蓝带)	P09-08003-002	W=21.3mm, T=0.06mm, 自粘式透明状	20.8M/1000PCS
④	REEL(蓝色卷盘)	P14-08004-001	外径: 330mm, 内径: 100mm, 内宽: 44.5mm	1PCS/1000PCS
⑤	折叠板	P08-15001-001	296*464*6mm	4PCS/10000PCS
⑥	平板	P07-15001-001	328*328*6mm	2PCS/10000PCS
⑦	CARTON (外箱)	P06-01001-001	350*350*335mm	1PCS/10000PCS



东莞市龙科电子科技有限公司
DONGGUAN LONGKE ELECTRONICS CO., LTD.

UNLESS OTHERWISE SPECIFIED
公差参考表

X.X	±0.00	X.X°	±0.00°	APPD:	核准:	PRODUCT NO:	产品品名:	TITLE:	PUSH MICRO SIM CARD 1.8H					
X.XX	±0.00	X.XX°	±0.00°	CHECK:	校对:	产品料号:	197-F063G23H-B07	DATE	2015.03.25					
X.XXX	±0.00	X.XXX°	±0.00°	DRAW:	绘图:	范小飞	SCALE	1:1	UNIT	mm	TYPE	CD	PAGE	1/1