



DATE	DR.BY	ECN.NO.	DESCRIPTION	MARK	VER.
06/06'16	何俊勇		NEW DWG		A0

NOTE:

1. MATERIAL:

- a. HOUSING: PBT
- b. CONTACT: PHOSPHOR BRONZE
(SURFACE PLATING: SN100u")

SEE ORDERING INFORMATION

2. ELECTRIC:

- a. CONTACT RESISTANCE: 30 MILLIOHMS MAX
- b. INSULATION RESISTANCE: 1000 MEGA OHMS MIN
- c. DIELECTNIC VOLTAGE: 750V AC ONE SEC LEVEL
- d. OPERATING TEMPERATURE: -25° C ~ +85° C

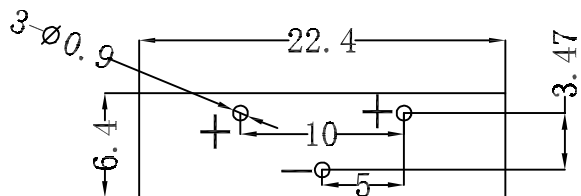
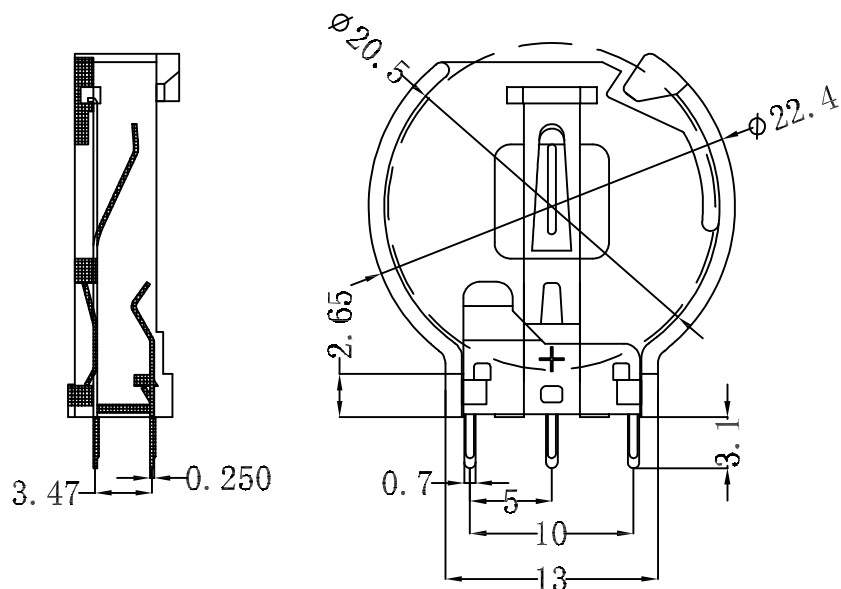

PCB Layout Diagram
Top View

3	TERMINAL (-)	1	PHOSPHOR BRONZE, T=0.25MM	Sn-Plating
2	TERMINAL (+)	1	PHOSPHOR BRONZE, T=0.25MM	Sn-Plating
1	HOUSING	1	PBT	BLACK
NO.	PART NAME	Q'TY	MATERIAL	PLATING & COLOR

-TOLERANCES- UNLESS OTHERWISE SPECIFIED 公差参考表		东莞市龙科电子科技有限公司 DONGGUAN LONGKE ELECTRONICS CO.,LTD :					
		TITLE: 产品品名: 电池座 DIP 90° Type					
X.X ±0.25	X.X* ±3.00°	APPD: 核准: 邹重庆	PRODUCT NO: 产品料号: 221-F032G01P-B10				
X.XX ±0.20	X.XX* ±1.00°	CHECK:dd 校对: 范小飞	DATE	SCALE	UNIT	TYPE	PAGE
X.XXX ±0.10	X.XXX* ±0.500°	DRAW: 绘图: 何俊勇	2017.02.10	1:1	mm	CD	1/1