

DATE	DR.BY	ECN.NO.	DESCRIPTION	MARK	VER.
5/31'16	何俊勇		NEW DWG		AO

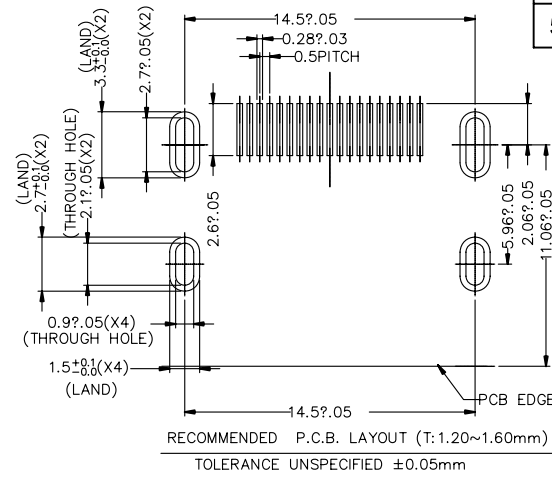

ORDER INFORMATION :

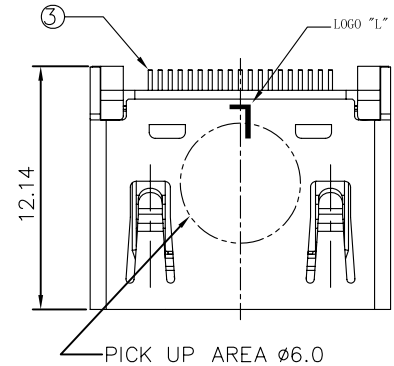
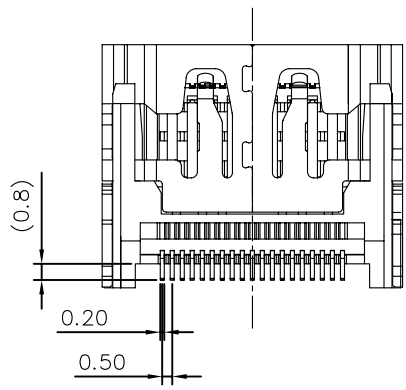
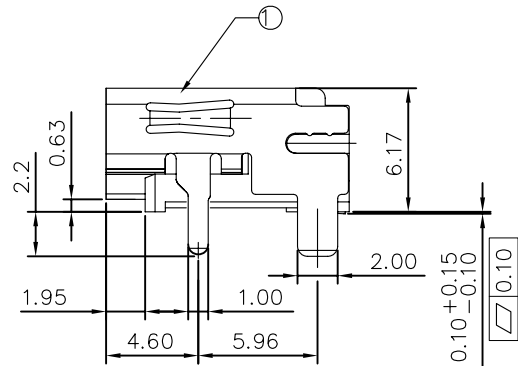
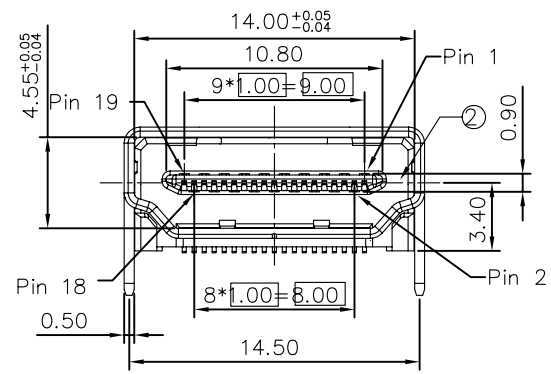
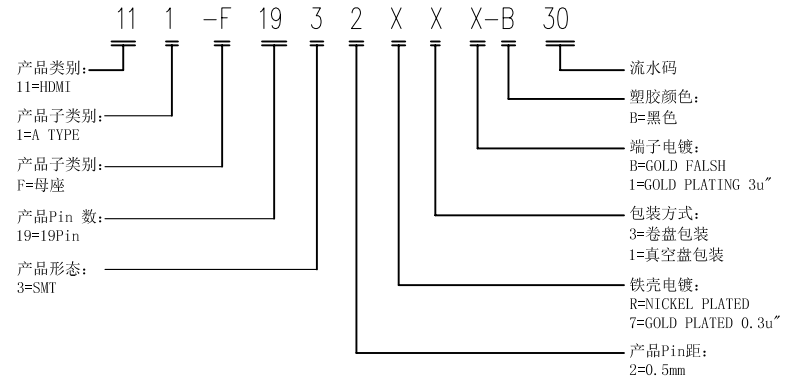

NOTES:

- OPERATING CURRENT: 0.5A MAX.
- OPERATION TEMPERATURE: -25°C TO +85°C
- DIELECTRIC WITHSTANDING VOLTAGE:
500Volts AC BETWEEN ADIACENT TERMINAL(UNMATE)
300Volts AC BETWEEN ADIACENT TERMINAL(MATE)
- INSULATION RESISTANCE:
100Mohm MIN.(UNMATED); 10Mohm MIN.(MATED)
- HDMI SPECIFICATION COMPLIANCE
- SHELL MATERIAL: SPCC, T=0.5mm, WITH BOTH SIDES SPRINGS
- Duration at Max. Process Temperature (seconds): 3
Lead-free Process Capability: Reflow Capable (SMT only)
Process Temperature max. : C260

ROHS COMPLIANCE

3	CONTACTS	19	COPPER ALLOY, GOLD PLATED OVER NICKEL ON CONTACT AREA AND 100u" MIN. TIN PLATED OVER NICKEL ON SOLDER TAILS
2	HOUSING	1	THERMOPLASTIC UL94V-0
1	SHELL	1	SPCC,NICKEL PLATED
ITEM	NAME	Q'TY	NOTES

-TOLERANCES- UNLESS OTHERWISE SPECIFIED 公差参考表		东莞市龙科电子科技有限公司 DONGGUAN LONGKE ELECTRONICS CO.,LTD.	
X.X ±0.25	X.X° ±3.00°	APPD: 核准: 刘威	TITLE: HDMI A TYPE, R/A 产品品名: SMT CONNECTOR
X.XX ±0.20	X.XX° ±1.00°	CHECK:dd 校对: 范小飞	PRODUCT NO: 产品料号: 111-F1932X3X-B30
X.XXX ±0.010	X.XXX° ±0.500°	DRAW: 绘图: 何俊勇	DATE SCALE UNIT TYPE PAGE 2016.05.31 1:1 mm CD 1/1